

Packing Your Success Stories



ISO 9001:2015

NATIONAL POUCH PACKING MACHINE

OFFICE & FACTORY :

Plot No. 35/1, Nemawar Road , 3inli
Square, Palda, Indore , MP

TEL : +91 9009292000 , 9229877377

UNIT 2nd :

Plot No. 280, jamniya khurd, Beside Dudhia
Gaon , Indore , MP

E-mail : nationalpouch@gmail.com

Web : www.nationalpouchpackingmachine.com

We are manufacturer of all kinds of packaging machines

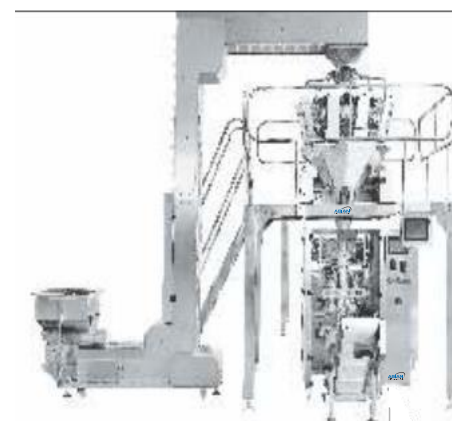

NATIONAL POUCH PACKING MACHINE

Your Identity Our
Technology



Packing Your Success Stories

Company

National pouch packing machine began in 1999 with a decision to produce the best packaging machinery possible for world-wide market. We are one of the most prominent names among the manufacturers, exporters, and suppliers of all type of pouch packing machines,. Our range of Automatic Packing Machine includes VFFS Machine with multi-head Weigher, VFFS Machine with volumetric Cup Filler, VFFS Machine with Servo Auger Filler, VFFS Machine for Small Sachet

Our engineers are not limited to yesterday's technology. New highly efficient, mechanical and electrical components are available and we are following the latest technology. Every machine component is designed with reliability, longevity, durability and a minimum of operator involvement as its top priorities. Our Machineries are highly appreciated by our clients for its high performance, durability, low maintenance and less power consumption.

National pouch packing machine. vision is to be the leading global resource for packaging, and its mission is to improve and promote members abilities to succeed in a global marketplace. We understand the importance and necessity for going the extra mile in today's business environment. We are globally renowned for making the highest quality equipment, offering responsive service and committing to meeting their customers needs. We are able to offer accurate delivery dates, control pricing, reduce our customers parts inventory. We have developed the good working relationships with many of our clients. They are satisfied with our products and after sale services.

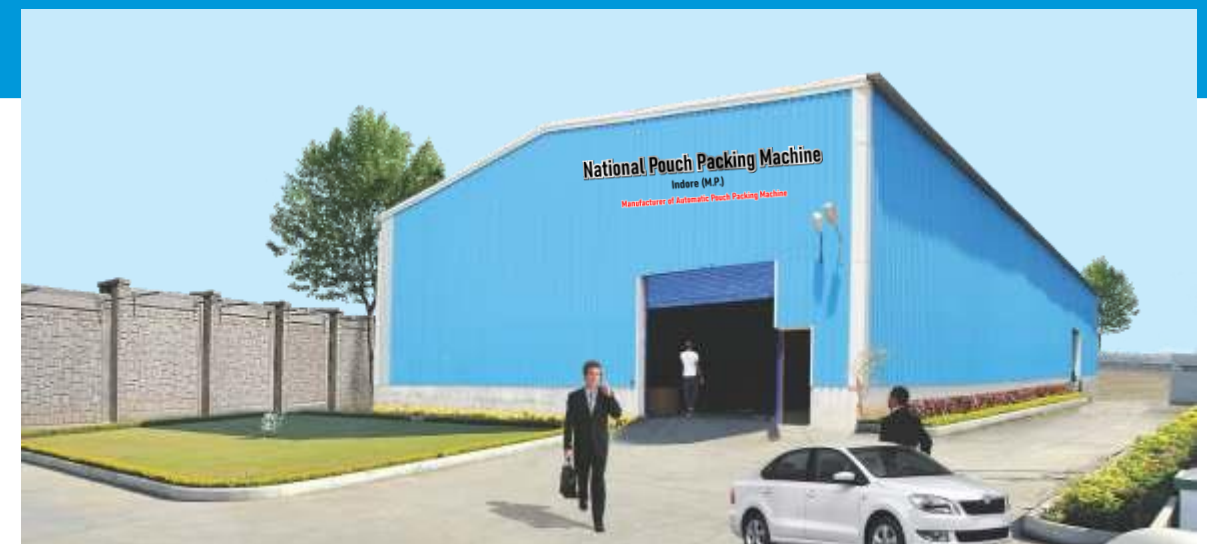



Packing Your Success Stories



Customer Satisfaction



Just in Time

- Top quality work and materials
- Assured delivery time
- Long-term co-operation
- Competitive prices Flexibility
- in solving problems

Our Motto

"We promise to deliver the best products to our clients, at the best possible prices with highest standards of quality."

www.nationalpouchpackingmachine.com



Packing Your Success Stories





Packing Your Success Stories



Packing Your Success Stories

APM 101 Collar Type Multihead Weigher

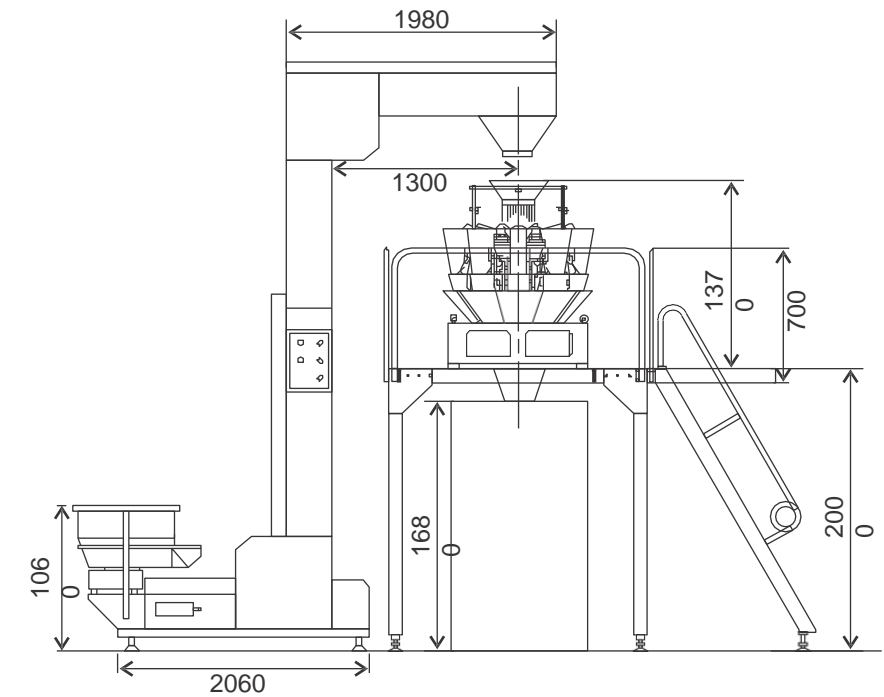

Automatic Form Fill & Seal Machine with Multihead Weigher for Chips, Fryms, Namkeen, Snacks, Grains & Free Flow Products Like Pulses, Soya Chunks, Whole Spices, Detergent Powder, Pesticides Etc. in Multihead Weigh Filler

Technical Specification

Packing Range	: 10gm to 1kg
Filling System	: (Multi Head Weigher) 10 Head Weigh Filler & 14 Head Weigh Filler
Filling Accuracy	: - /+ 0.1%
Type of Sealing	: Center Seal
Film Size	: 100mm-500mm width x 100mm-360mm length Film Roll Type
	: Laminated Film in Roll Supported Film E.g. Aluminum Foil Pe
Speed	: 45 to 60 bag/min (Varies with the nature of product & filling range)
Power	: 3kw 230v /AC /Single Phase /50hz
Wooden Case	: 1300mm x 1000mm x 1000mm (HxWxL)
Machine Size	: 72" x 85" x 126
Weight	: 1400kg (Approx)
Compressed Air	: 6 CFM @ 6 bar
Optional	: Batch Coding Device



Packing Your Success Stories

APM 102 Collar Type Four Head Weigher



Automatic Form Fill & Seal Machine with Four Head Weigh Filler for Grains & Free Flow Powder Products Like Pulses, Rice, Tea, Sugar, Namkeen, Whole Spices, Detergent Powder, Pesticides Etc. in Four Head Weigh Filler

Technical Specification

Packing Range	: 50g to 1kg (1kg - 5kg)	Speed	: 10 to 30 bag/min depend on the nature of the product
Type of Sealing	: Four head Weigh Filler	Power	: 5 KW
Film Size	: Center Seal : 250mm- 600mm width x 100mm- 450mm Length	Optional	: Batch Coding Device, Batch Cutting Device, Z Elevator
Film Roll Size	: OD 250 to 400mm max. ID film Reel Pipe 75mm	Wooden Case	: 2500mm x 1200mm x 1200mm (HxWxL)
Film Roll Type	: Laminated Film	Machine Size	: 2800mm x 1700mm x 1400mm (LxWxH)
		Machine Weight	: 850kg. (Approx)



Packing Your Success Stories

APM 103 Collar Type Two Head Weigher



Automatic Form Fill & Seal Machine with Two Head Weigh Filler for Grains & Free Flow Powder Products Like Pulses, Rice, Tea, Sugar, Namkeen, Whole Spices, Detergent Powder, Pesticides Etc. in Two Head Weigh Filler

Technical Specification

Packing Range	: 50g to 1kg	Speed	: 8 to 14 Pouches per minute depend on the product nature
Type of Sealing	: Two Head Weigh Filler	Power	: 4KW Three Phase
Film Size	: Center Seal : 200mm-520mm width x 120mm-360mm Length	Optional	: Batch Coding Device, Batch Cutting Device, Z Elevator
Film Roll Size	: OD 250 to 300mm max. ID Film Reel Pipe 75mm	Wooden Case	: 2300mm x 1100mm x 1200mm (HxWxL)
Film Roll Type	: Laminated Film	Machine Size	: 2600mm x 1600mm x 1300mm (LxWxH)
		Machine Weight	: 750kg. (Approx)



Packing Your Success Stories

APM 104 Semi Pneumatic Cup Filler



Automatic Form Fill & Seal Machine with Cup Filler for Grains & Free Flow Powder items Like Rawa, Broken Wheat, Detergent, Tea, Coffee, Namkeen, Puffs, Pesticides Etc. in Volumetric Cup Filler

Technical Specification Filling

System	: Volumetric Cup Filler
Filling Accuracy	: +/-0.1% - +/-0.2%
Sealing Type	: Center Seal /3 Side Seal
Filling Range	: 10gm to100 /100gm to 250gm
Film Role Material	: Laminated Film
Speed Capacity	: 25 to 40 Bag/min (Varies with the Nature of Product & Filling Range)
Machine Size	: 1050mm x 990mm x 1900mm (L x W x H)

PLC	: Delta
TC	: Selectron
Contact Part	: SS 304
Power	: 2.5Kw
Optional	: Batch Coding Device, Batch Cutting Device Gas Flushing Unit
Machine Weight	: 450kg (Approx)



Packing Your Success Stories

APM 105 Collar Type Fully Pneumatic Cup Filler



Automatic Collar Type Form Fill & Seal Machine with Cup Filler for Grains & Free Flow Powder items Like Rawa, Broken Wheat, Detergent, Tea, Coffee, Namkeen, Fryms, Peanut, Puffs, Soya Chunk, Pesticides Etc. in Volumetric Cup Filler

Technical Specification

Packing Range	: 1. (20gm to 100gm) 2. (100gm to 500gm) 3. (500gm to 1000gm)
Filling System	: Volumetric Cup Filler
Type of Sealing	: Center Seal
Packing Material	: Powder, Grains, Etc
Film Size	: 200mm-420mm width x 100mm-550mm length
Film Roll Size	: OD 250 to 400mm max. ID film reel pipe 75mm

Film Roll Type	: Laminated Film
Speed	: 40 to 60 bag/min (Varies with the nature of product & Filling range)
Power	: 3 KW 230V /AC /Single Phase/ 50hz
Optional	: Batch Coding Device, Batch Cutting Device Gas Flushing
Wooden Case	: 1700mm x 1000mm x 1100mm (H x W x L)
Machine Size	: 1050mm x 990mm 2100(L x W x H)
Machine Weight	: 750kg. (Approx)



APM 106 Semi Pneumatic Servo Auger Filler



Automatic Semi Pneumatic Form Fill & Seal Machine with Servo Auger Filler for Sticky Powder Products Like Spices, Wheat Flour, Coffee Powder, Henna, Pesticides Etc. in Servo Auger Filler

Technical Specification

Filling System	: Servo Auger Filling
Filling Accuracy	: +/- 1 to 2% Depend upon nature of product
Sealing Type	: Center Seal / 3Side Seal
Filling Range	: 50gm to 500gm
Packing Material	: Sticky Powder
Size of Bag/ Pouch:	W-100 to 360mm L-80 to 130mm
Machine Size	: 2500mm x 800mm x 900mm (HxWxL)

Wooden Case	: 2650mm x 1000mm x 1000mm (HxWxL)
PLC	: Delta /Fuji
Contact Part	: SS 304
Filling System	: Servo Auger Filler
Power	: 220v Ac Single Phase And Three Phase
Optional	: Batch Coding Device, Screw Conveyor
Machine Weight	: 650kg (Approx)



APM 107 Collar Type Fully Pneumatic Servo Auger Filler



Automatic Collar Type Form Fill & Seal Machine with Servo Auger Filler for Sticky Powder Products Like Spices, Wheat Flour, Gram Flour, Milk Powder, Ice Cream Powder, Pesticides Etc. in Servo Auger Filler

Technical Specification

Filling System	: Servo Auger Filling
Filling Accuracy	: +/- 0.1% Depend upon nature of product
Sealing Type	: Center Seal
Filling Range	: Up to 1000gm
Packing Material	: Sticky Powder
Film Role	: 100To 400mm-W/80mm to 240mm-L
Speed Capacity	: 30 to 45 Pouch per minute
Machine Size	: 2500mm x 900mm x 1000mm (HxWxL)

Wooden Case	: 2650mm x 1200mm x 1200mm (HxWxL)
PLC	: Delta /Fuji
Contact Part	: SS 304
Power	: 440v ThreePhase
Optional	: Batch Coding Device, Batch Cutting Device Screw Conveyor
Machine Weight	: 700kg (Approx)



Packing Your Success Stories

APM 108 Collar Type Servo Bagger Servo Auger Filler



Automatic Form Fill & Seal Machine with Servo Auger Filler for Sticky Powder Products Like Spices, Wheat Flour, Gram F Milk Powder, Ice Cream Powder, Pesticides Etc. in Servo Auger Filler

Technical Specification

Packing Range : 1. (100gm to 500gm) 2. (500gm to 1000gm)	PLC : Delta /Fuji
Filling System : Servo Auger Filler Type of Sealing : Center Seal	Speed : 40 to 60 PPM Depend On The Product Nature &Weight
Film Size : 180mm-520mm width x 100mm-360mm Length	Power : 5 KW Three Phase
Film Roll Size : OD 250 to 300mm max. ID Film Reel Pipe 75mm	Optional : Batch Coding Device, Batch Cutting Device, Screw Conveyor
Film Roll Type : Laminated Film	Wooden Case : H 2200 mm, W 1000mm, L 1200mm
	Machine Weight : 750kg. (Approx)



Packing Your Success Stories

APM 109 Collar Type Servo Auger Filler (High Speed)



Automatic Form Fill & Seal Machine with Servo Auger Filler for Sticky Powder Products Like Spices, Gram Flour, Milk Powder, Ice Cream Powder, Pharmaceutical Powder, Pesticides Etc. in Servo Auger Filler

Technical Specification

Packing Range : 5gm to 50gm	Speed : 60 to 90 Pouches Per Minute Depend On The Product Nature
Filling System : Servo Auger Filler	Power : 5KW ThreePhase
Type of Sealing : CenterSeal	Optional : Batch Coding Device, Batch Cutting Device, Screw Conveyor
Film Size : 120mm-250mm width x 80mm-200mm Length	Wooden Case : H 2200 mm, W 1000mm, L 1200mm
Film Roll Size : OD 250 to 300mm max. ID Film Reel Pipe 75mm	Machine Weight : 650kg. (Approx)
Film Roll Type : Laminated film	



Packing Your Success Stories

APM 110 Mechanical F.F.S. Machine Cup Filler



Automatic Form Fill and Sealing Machine for Filling Dry, Free Flowing Products Like Detergent Powders, Sugar, Salt, Tea Dust, Bhujia, Whole Spice, Chemical Etc.

Technical Specification

Capacity	: 5gm to 20gm	Speed Capacity	: 35 to 60 Pouch per minute
Filling System	: Cup Filler	Contact Part	: SS 304
Filling Accuracy	: +/- 0.1 %	Dimension	: 780 x 650 x 1950mm (LxWxH)
Sealing Type	: Center Seal / 4 Side Seal, 3 Side Seal	Power	: 2kw Single Phase
Packing Material	: Laminated Film	Optional	: Batch Coding Device
Film Size	: 160mm-250mm Width 140mm-200mm Length	Machine Weight	: 450kg (Approx)



Packing Your Success Stories

APM 111 Mechanical F.F.S. Machine Piston Filler



Automatic Form Fill & Seal Machine for Free Flowing Liquid and Semi Liquid to Pack Products Like Shampoo, Honey, Coconut Oil, Tomato Puree, Oil, Grease, Paste and any other Free Flowing Materials in Piston Filler

Technical Specification

Packing Rang	: 1. (2ml to 20ml) 2. (20ml to 50ml) 3. (50ml to 100ml)	Speed Capacity	: 35 to 50 Pouch per minute
Filling System	: Volumetric Piston Filing	Machine Size	: 780 x 650 x 1950mm (LxWxH)
Filling Accuracy	: +/- 0.1 %	Contact Part	: SS 304
Sealing Type	: Center Seal / 4 Side Seal, 3 Side Seal	Power	: 2kw Single Phase
Filling Range	: Up to 100ml	Optional	: Batch Coding Device
Packing Material	: Liquid & Semi Liquid	Machine Weight	: 430kg (Approx)



Packing Your Success Stories

APM 112 Multi Track Packing Machine



Automatic Multi-Track Form Fill & Seal Machine with Piston Filler for Liquid and Semi Liquid Products Like Shampoo, Ketchup, Oil, Cream, Pharma products & Pesticide products

Technical Specification

Packing Range	: 2ml to 50ml (2gm to 50gm)	Speed	: 50 to 100 Stock Per Minute (Varies with the nature of product & Filling range)
Filling System	: Piston Filler, Cup Filler Four	Power	: 4 KW 440V /AC /Three Phase
Sealing Type	: Side Seal Laminated Film	Optional	: Batch Coding Device, Batch Cutting Device
Packing Material	: 400mm-900mm width x		Auto Lubrication, GMP Model, Gas Flushing
Film Size	: 50mm-150mm length		Unit Level Sensor
	OD 250 to 400mm max.	Machine Size	: 2200mm x 1700mm x 2300mm
Film Roll Size	:	Machine Weight	: 1500kg (Approx)
	ID film reel pipe 75mm min		
Film Roll Type	: Laminated Film		



Packing Your Success Stories

APM 113 Automatic Rotary Pouch Packing Machine



The Granules packing machine is suitable for granule material, s Melon seeds, Nuts, Candy, Raisins, Chinese Wolfberry, Red dates, Potato chips, Cookies and other solid material automatic packing.

Technical Specification

Bag material	: Laminated film/PE/PP	Voltage	: 380v 3phase 50/60hz
Bag pattern	: Stand-up with zipper & stand-up with spout, flat bag,	Total power	: 5.5KW
Max filling weight	: 10-5000ml	Compress air	: 0.6m ³ /min
Filling accuracy	: 0.5-1%	Detecting device	: 1.No ribbon, alarm and Emergency stop 2.No pouch or pouch open error, no filling, no sealing
Bag size	: Type 1 W:100-200mm L:100-350mm Type 2 W:150-260mm L:100-350mm Type 3 W:200-300mm L:200-450mm	Safety device	: 1.Open the door, alarm a Emergency stop(Optional) 2.The air pressure not enough, alarm 3.the sealing temperature anomaly, alarm
Speed	: 10-60bags/min		



Packing Your Success Stories

APM 114 Mechanical Horizontal Flow Wrap Machine



Automatic Horizontal Flow Wrap Machine with Manual Feeding for Packing solid products like Chocolate, Biscuit, Lollypop, Soap, Peanut Candy, Ice Candy, Scrub Pad, Auto Parts, Industrial Parts, any solid piece Etc.

Technical Specification

Filling System	: Automatic/ Manual	Power	: Motor 1.5 HP DC with DC drive 220V / single Phase, Load -3kw
Type of Sealing	: Center Seal (Pillow Type)	Machine Size	: 1080mm x 1700mm x 1800(approx..)
Packing Material	: Chocolate, Biscuit Etc.	Machine Weight	: 700kg (Approx)
Film Roll Type	: Laminated film in roll supported film E.g., Aluminum Foil Pe, PP		
Speed	: Approx 40 to 120 pouches/ min(Depend upon the Packet size)		



Packing Your Success Stories

APM 115 Horizontal Flow Wrap Machine (High Speed)



Automatic Horizontal Flow Wrap Machine with Manual Feeding for Packing solid products like Chocolate, Biscuit, Lollypop, Soap, Peanut Candy, Ice Candy, Scrub Pad, Auto Parts, Industrial Parts, any solid piece Etc.

Technical Specification

Model	HFFS 250	HFFS 320	HFFS 450
Max Film Width	250mm	320mm	450mm
Bag Length	65mm - 190mm	120mm-280mm	65mm-190mm
	120mm - 280mm	130mm-450mm	
Bag Width	30mm-110mm	50mm-160mm	60mm-220mm
Max Product Height	40mm	40mm	80mm
	55mm	55mm	
Speed	40-230 PPM	40-230 PPM	30-180 PPM
Power	MOTOR 1 H.P	MOTOR 1 H.P	MOTOR 1 H.P
	2.5KW SINGLE PHASE	2.5KW SINGLE PHASE	2.5KW SINGLE PHASE
Machine Size	1800mm L	1800mm L	1800mm L
	1000mm W	1000mm W	1000mm W
	1360mm H	1360mm H	1360mm H
Machine Weight	700kg (Appx.)	800 (Appx.)	900(Appx.)



Packing Your Success Stories



Packing Your Success Stories

Filler & Accessories



10 Head Weigher



14 Head Weigher



Four Head Weigher



Two Head Weigher



Output Conveyor



Bucket Elevator



Working Platform



Timing Hopper



Rotary Table



Inclined Screw Conveyor